Industrial Magnetic Devices

Table of Contents

What to know before ordering	3
Super Latch Magnets	4
Powerful Handle Magnets	5
Holding and Retrieving Magnets	6
Heavy Duty Holding and Retrieving Magnets . .	7
Round Base Magnets	8
Rectangular Base Magnets	9
Magnetic Tool Holders	10
Magnet Assemblies	10 and 11
Alnico and Ceramic	
Material Handling Magnets	12
Blocks, Welding Fixtures, Grippers	
Standard Plate Magnets	13
Heavy Duty Plate Magnets	13
Separation Magnets.	15, 16, and 17
Hopper Grates, Tubes, Pulleys, and Pipe Plug Filters	
Water Treatment Magnets	18 and 19
Inventory I.D. Magnets.	20
Office Magnets	21
Magnetic Hangers, Hooks, Clamps and Clips	
Handy Magnets.	22
Telescoping Magnetic Pickup, Bend-It Magnet,	
Screwdriver Magnetizer/Demagnetizer,	
and Hold Everything Magnet	
Material Handling Magnets	23
Multi-lifts, Permanent Lifts	

About the company

The Magnet Source™ manufactures and distributes all types of magnetic products for industrial, commercial, and consumer use. Master Magnetics, Inc., the main manufacturing facility located in Colorado, was founded in 1976. **Miami Magnet Company** (founded 1956), **A-L-L Magnetics, Inc.** (1985), and **Master Magnetics East** (1994) joined **Master Magnetics, Inc.**, using the exclusive trade name, **The Magnet Source™**. Today, we serve customers across the U.S. and abroad.

Our large inventory and warehousing capability allow us to serve a wide range of customers with many types of applications. Currently, we have over 15 million magnets in stock. We have excellent resources for raw material magnets and the machinery to cut, grind, and magnetize magnets to meet customer applications. Our other manufacturing capabilities allow us to produce a wide variety of magnetic assemblies. ***We want to be your best source in the magnetic field!***

Three locations to serve you:

U.S.A. and International:

MASTER MAGNETICS, INC.
607 S. Gilbert St., Castle Rock, CO 80104
Toll Free: **888.293.9399**
Local: 303.688.3966

California and Hawaii:

A-L-L MAGNETICS, INC.
2831 Via Martens, Anaheim, CA 92806
Toll Free: **800.262.4638**
Local: 714.632.1754

Southeastern U.S.A.:

MIAMI MAGNET CO.
6073 N.W. 167th St., Ste. C26
Miami, FL 33015
Toll Free: **800.222.7846**
Local: 305.823.0641

What to Know Before Ordering

Read this section first before ordering. This section will give you a comprehensive understanding of our policies.

Permanent Magnetism Guarantee

The magnetic devices in this catalog are all made from permanent magnet material. We guarantee, under normal use, that these magnets will remain magnetized or we will remagnetize them. There is an expected loss of strength of 1/2 of 1% per century.

Magnetic Strength Pull Test Methodology

We rate our magnets pull strength by pounds of pull in a vertical test. The magnets entire magnetic surface is tested against a 1/4" ground steel plate. If the item you wish to lift is thinner than 1/4", is not ground flat, or does not cover the entire magnetic surface, actual holding capacity could be much lower. Painted surfaces also tend to reduce tested strengths.

Stock and Delivery

With over 15 million magnets in stock and over 3,200 part numbers, we are usually able to offer the variety and quantity of magnets that you need shipped within 24 hours.

Custom Assemblies and Special Orders

We can custom manufacture magnetic assemblies to fit your application. A mechanical drawing and an explanation of the application are necessary in order to begin the design assistance process. Custom assemblies and some of the items in this catalog are non-stock, made to order items and are typically considered special order items.

Special Orders

A 25% to 50% deposit is required for special order items. Lead times may vary. Special order items are non-returnable and non-refundable.

Payment Terms

Acceptable methods of payment include VISA, MasterCard, COD, Check/Money Order/Cash in advance, or on pre-approved open account. All items in this catalog are shipped F.O.B. origin.

Minimum Order

Low minimum order; only \$30.00

Return Policy

Returns may be subject to a 15% restocking fee. No returns after 30 days. No returns on special and custom orders. Please contact your customer service representative before attempting to return an item. No items will be accepted without a Return Goods Authorization (RGA) number.

Notice to Purchasers

All statements, technical information, and recommendations contained herein are based on tests we believe to be reliable, but the accuracy or completeness thereof is not guaranteed, and the following is made in lieu of all warranties, express or implied. Seller's and manufacturer's only obligation shall be to replace such quantity of the product proved to be defective. Neither seller nor manufacturer shall be liable for any injury, loss or damage, direct or consequential, arising out of the use of or the inability to use the product. Before using, user shall determine the suitability of the product, for its intended use, and user assumes all risk and liability whatsoever in connection therewith.

No statement or recommendation contained herein shall have any force or effect unless in an agreement signed by both officers of seller and manufacturer.



Super Latch Magnets

Super latch magnets lift, suspend, hold and retrieve metal objects up to 100 times their own weight!



Mount magnet to step ladder or wall to conveniently hold hand tools. Use to hold trouble light, door signs, or as a door stop.

Super Latch Magnets

Use as door stops, small tool holders, magnetic clamps, to separate magnetic from non-magnetic materials and more. Attach to a dowel or board to make a small, hand-held magnetic tool for picking up nails, screws, washers etc. Permanent magnetism guaranteed! All super latch magnets are red.

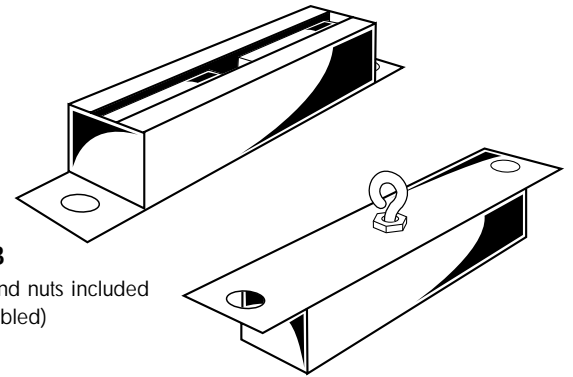

LM-100B
Eyebolts and nuts included
(not assembled)

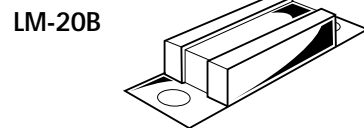
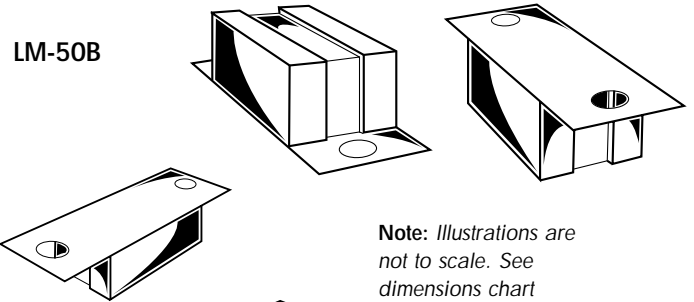

LM-20B

Note: Illustrations are not to scale. See dimensions chart

Make a magnetic rack to hold items for painting.

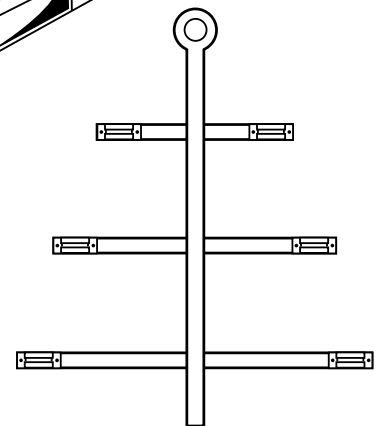

Type A
Side View

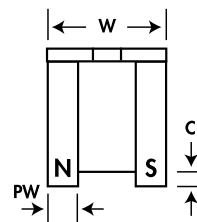

Type A
Front View

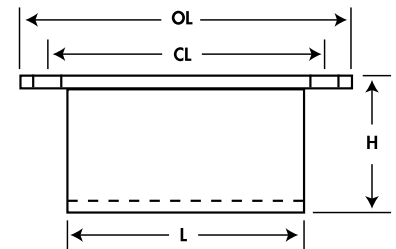

Super Latch Magnets

Part No.	Type	Weight Pounds	Pounds Pull	Dimensions/Inches							Hole Sizes
				W	L	H	PW	C	CL	OL	
LM-20B	A	0.18	20	0.75	2	0.562	0.187	0.125	2.50	3	0.25
LM-50B	A	0.34	50	0.75	2	1.062	0.187	0.125	2.50	3	0.25
LM-100B	A	0.82	100	0.75	2	1.062	0.187	0.125	5.50	6	0.25

Key: W = Width, L = Length, H = Height, PW = Pole width, C = Clearance of magnet, CL = From hole center to hole center, OL = Overall length
All dimensions approximate

Powerful Handle Magnets

Lift, suspend, hold and retrieve metal objects up to 100 times their own weight!



Retrieve iron objects. Remove nails, screws and other iron objects from degreasing and paint tanks.

Powerful Handle Magnets

Use magnets to clean up scattered iron objects such as screws, nuts and bolts, to separate magnetic from non-magnetic materials, plus much more. Permanent magnetism guaranteed! All powerful handle magnets are red.



Use to transfer sheets of steels for any application.

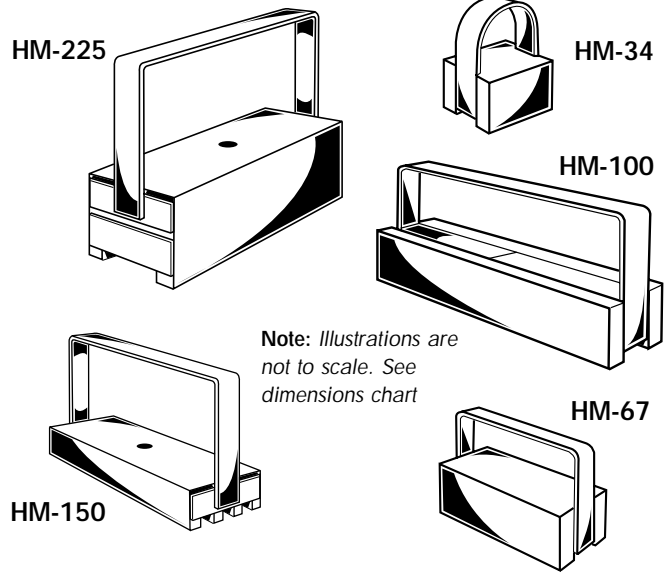

Note: Illustrations are not to scale. See dimensions chart

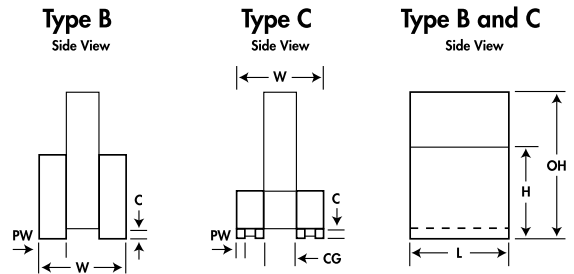

Powerful Handle Magnets

Part No.	Type	Weight Pounds	Pounds Pull	Dimensions/Inches						
				W	L	H	PW	C	OH	CG
HM34	B	0.25	25	0.75	1.062	1.0	0.187	0.125	2.0	0.395
HM67	B	0.42	50	0.75	2.0	1.0	0.187	0.125	2.0	0.395
HM100	B	0.75	100	0.75	4.0	1.0	0.187	0.125	2.375	0.395
HM150	C	2.26	150	2.00	5.0	1.0	0.187	0.125	5.5	0.437
HM225	B	5.04	225	2.00	5.25	2.0	0.375	0.250	4.5	1.187

Key: W = Width, L = Length, H = Height, PW = Pole width, C = Clearance of magnet, OL = Overall length, CG = Center gap
All dimensions approximate

Holding and Retrieving Magnets

Hold, lift or hang objects from metal walls, beams and doors.

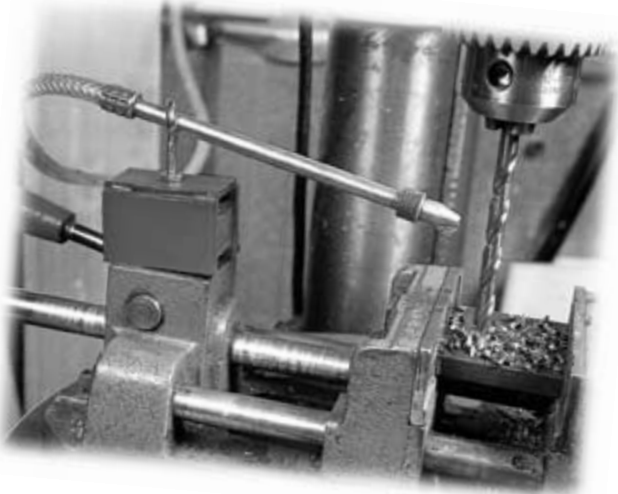

These magnets can also be screwed or bolted to most surfaces. Attach a rope or chain to the eyebolt and go fishing for metal objects in tanks, vats, waterways or hard-to-reach places. Also can be used to hold spray nozzles, hoses, temporary wiring and more. Painted red.

- Use as magnetic door catch
- Keep cooling hoses in place
- Attach to wooden dowel to pick up ferrous materials

37016B

10-24 eyebolt and nut included (not assembled)

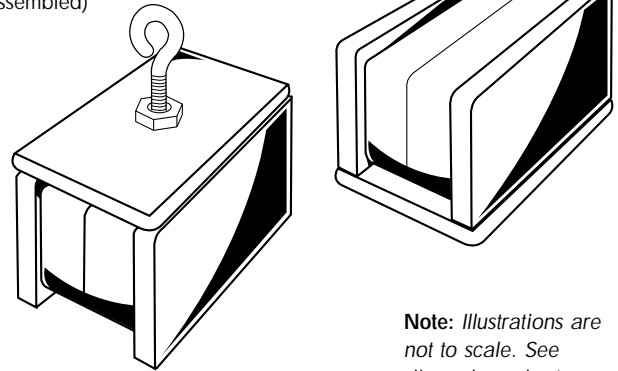

Note: Illustrations are not to scale. See dimensions chart

370X32B

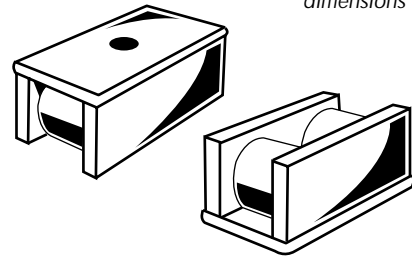

370-3Bulk

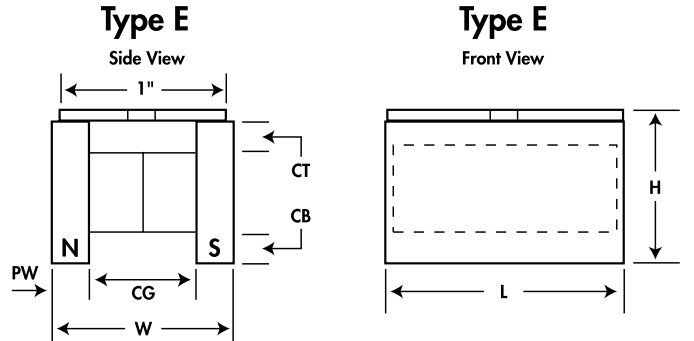
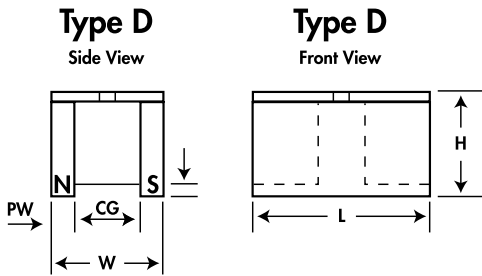
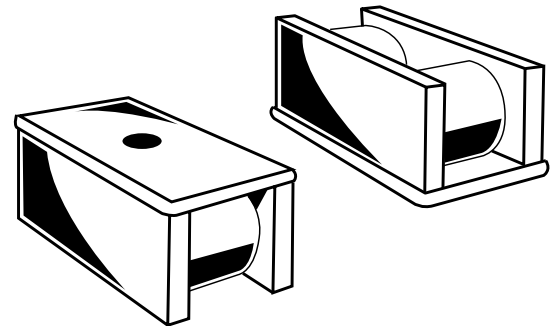

Holding and Retrieving Magnets

Part No.	Type	Weight Pounds	Pounds Pull	Dimensions/Inches							Hole Sizes
				W	L	H	PW	CB	CT	CG	
370X32B	D	0.08	5	0.625	1.375	0.562	0.125	0.062	-	0.375	0.187
370-3BULK	D	0.12	18	0.625	1.750	0.812	0.125	0.125	-	0.375	0.187
37016B	E	0.63	50	1.250	2.000	1.375	0.250	0.187	0.187	0.750	10-24 T

Key: W = Width, L = Length, H = Height, PW = Pole width, CB = Bottom clearance of magnet, CT = Top clearance of magnet, CG = Center gap, All dimensions approximate

Heavy Duty Holding and Retrieving Magnets

Hundreds of commercial and industrial uses. Models on this page include hardware and are painted red.



Tie a rope or chain to the magnet to retrieve sunken treasures.

Heavy Duty Holding and Retrieving Magnets

Similar to retrieving magnets on page 6, but stronger—lifting up to 225 lbs. Remove steel parts from tumbling media; attach to rod for tank cleaning. Separate metal particles from water, oil or other liquids. Move parts in and out of degreasing tanks. Move hardware from kegs or storage bins.

Note: Illustrations are not to scale. See dimensions chart

370150

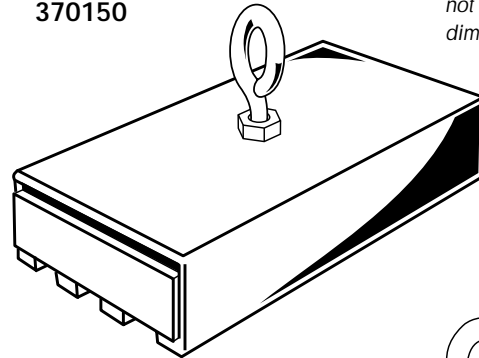

370-30B

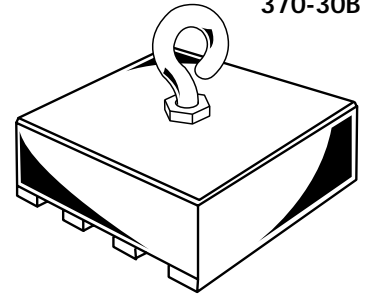

37010B

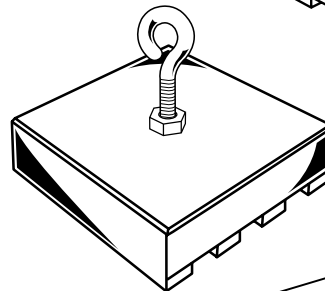

370225

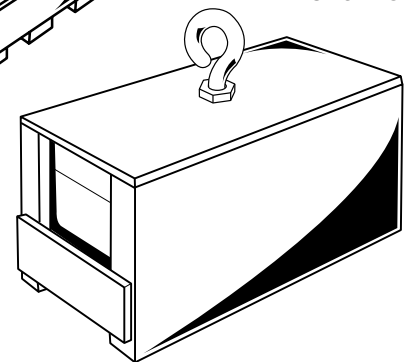

All include eye-bolt and nuts. (not assembled)

Type F
Side View

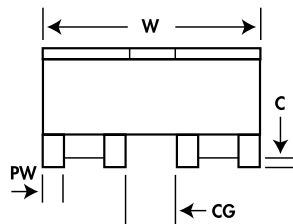

Type G
Side View

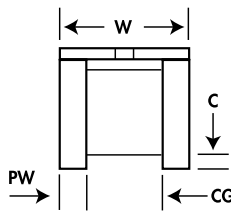

Type F and G
Side View

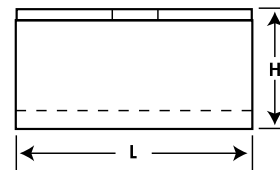

Heavy Duty Holding and Retrieving Magnets

Part No.	Type	Weight Pounds	Pounds Pull	Dimensions/Inches						Hole Size
				W	L	H	PW	C	CG	
37010B	F	0.42	40	2	2	0.562	0.187	0.125	0.437	0.25
370-30B	F	0.83	100	2	2	1.062	0.187	0.125	0.437	0.25
370150	F	1.75	150	2	5	1.062	0.187	0.125	0.437	1/4-20TH
370225	G	4.50	225	2	5	2.000	0.375	0.187	1.187	1/4-20TH

Key: W = Width, L = Length, H = Height, PW = Pole width, C = Clearance of magnet, CG = Center gap.

All dimensions approximate

Round Base Magnets

Because of their low cost, high holding power, a compact design, these magnetic bases are very versatile.

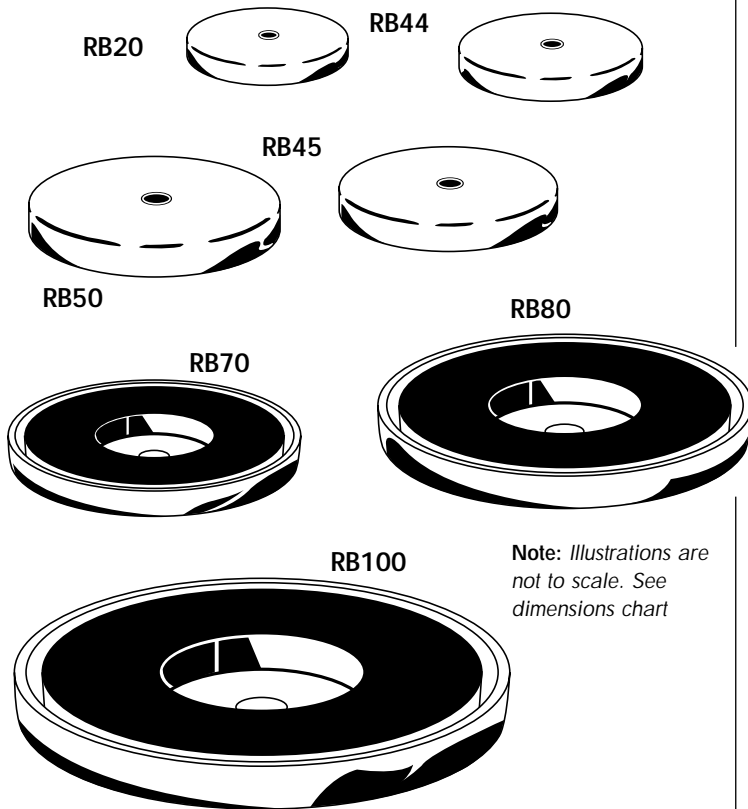

Note: Illustrations are not to scale. See dimensions chart

Round base magnets are constructed of powerful ceramic ring magnets encased in plated steel cups, with an attachment hole in the center. Position, hold, or hand inspection equipment, indicator gauges, lamps, antennas and more.

Round Base Magnets

Part No.	Standard Plating	Weight Pounds	Pounds Pull	Dimensions/Inches			
				OD	T	CH	MID
RB20	Nickel	0.03	4	1.21	0.171	0.125	0.187
RB44	Nickel	0.09	12	1.73	0.305	10-24TH	0.885
RB45	Nickel	0.07	16	1.42	0.265	0.187	0.375
RB50	Nickel	0.14	25	2.04	0.290	0.200	0.865
RB70	Nickel	0.33	65	2.65	0.360	0.250	1.000
RB80	Nickel	0.48	95	3.19	0.440	0.280	1.200
RB100	Chrome	1.44	200	4.90	0.500	0.500	1.750

Key: OD = Overall diameter, T = Thickness, CH = Center hole size, MID = Magnet's inside diameter.
All dimensions approximate

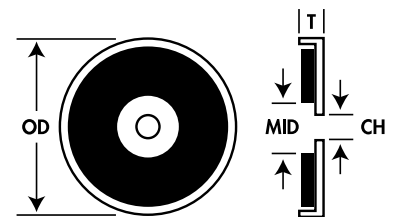

Hang banners or hold large tarps to metal surfaces.

Add a drawer knob to make a powerful holder for posters, letters, or notes on iron walls, or filing cabinets.

Hold towing lights, emergency lights, or trouble lights to a vehicle.

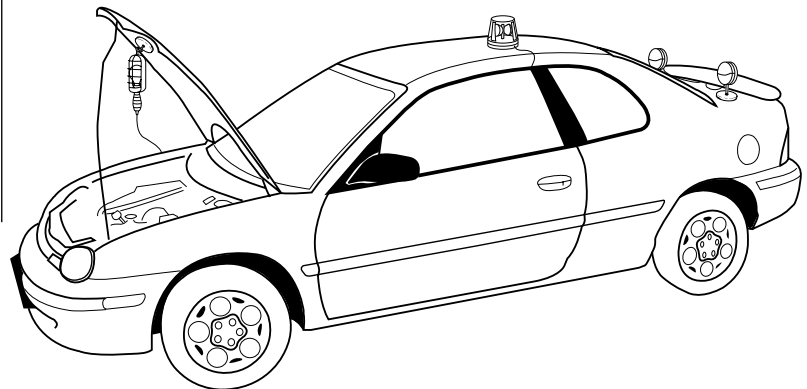

Rectangular Base Magnets

These versatile magnets can be used for holding fixtures, door latches, and other applications.

Latch Magnet Assembly - Part No.: CA41L

A strong ceramic magnet is "sandwiched" between two zinc plated steel pole pieces to form a powerful latch magnet assembly. (12 lbs. pull) Assembly held together magnetically.

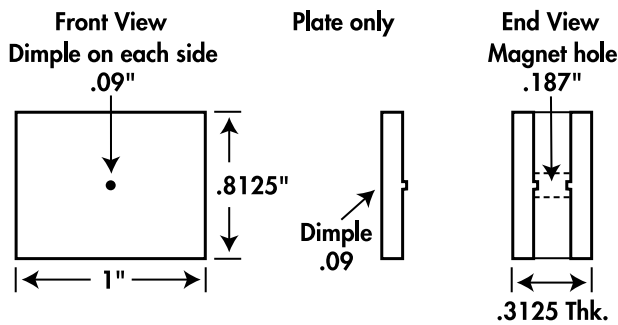

Note: Illustrations are not to scale. See dimensions chart

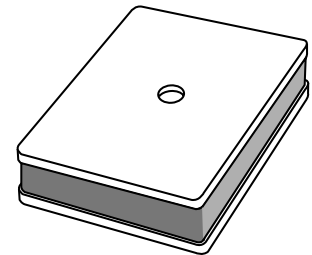

Latch Magnet Channel Assembly - Part No.: CA403

A strong ceramic magnet is fixed into a zinc plated steel channel to form a latch magnet assembly with holding power on one large surface. It features a center hold for mounting. Used mainly as a door latch, it's also great for holding key rings, nameplates, nozzles, fixtures or other ferrous metal objects. (7 lbs. pull)

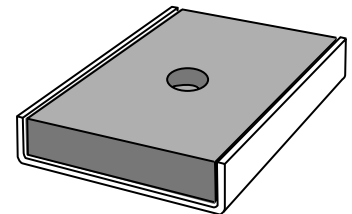
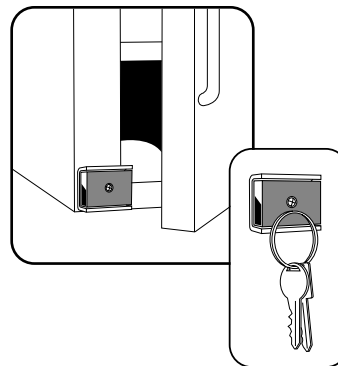
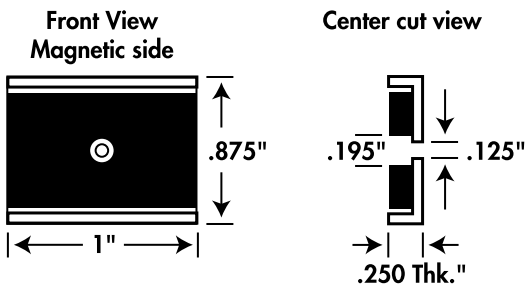

Large Channel Magnet Assembly - Part No.: CBA360

Three powerful, rectangular ceramic magnets are fixed in a zinc plated steel channel with mounting holes. Car dealerships use it as a license plate holder for test drives. This assembly also makes an excellent tool holder, sign holder and more. (25lbs. pull) Screws not included.

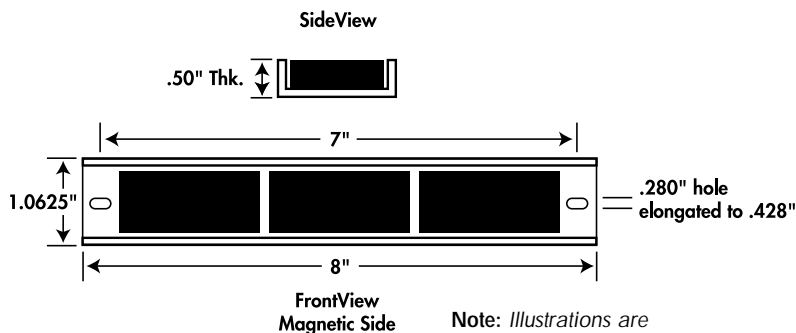

Note: Illustrations are not to scale. See dimensions chart



Magnetic Tool Holders

Our super-strong magnetic tool holders will over-power the average wimpy magnets. Their pull strength is over 20 lbs. per inch!

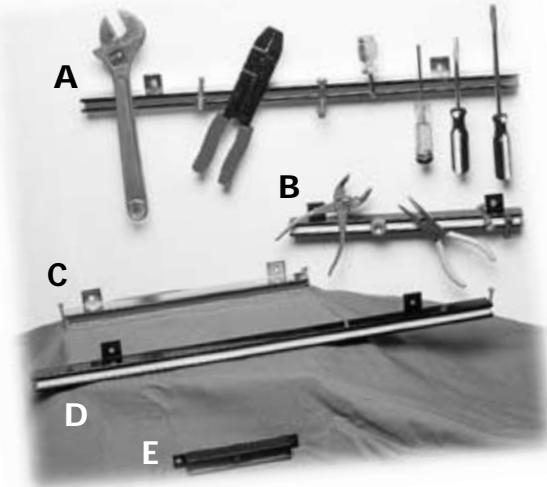

Magnetic Tool Holders

Heavy-duty permanent magnet assemblies hold large or small tools and metal parts firmly and securely in place.

Perfect for workshops, garages, manufacturing facilities, maintenance areas, even inside trucks and vans —anywhere metal tools need to be kept, organized, or easily accessible.

When mounted to any surface, our tool bars are held firmly in place by welded tabs, with 1/4" holds for screws, which are more secure and durable than metal clips or rubber strips. Mounting hardware included.

"E" to the left can be used as a toll holder, fixture device, saw guide, or with an eyebolt installed, a 100 pound retrieving magnet.

Magnetic Tool Holders

Part No.	Pictured No.	Length Inches	Color	Hole Size	Holes Center to Center	Mounting Hardware
AMC-24	A	24	Chrome/Red	0.25	16.0"	2 Screws
AM-2	B	13	Black/Yellow	0.25	10.0"	2 Screws
AMC-13	C	13	Chrome/Red	0.25	10.0"	2 Screws
AM-1	D	24	Black/Yellow	0.25	16.0"	2 Screws
AM3-RM100	E	6	All Black	0.25	2.75"	Eyebolt & 2 nuts

All dimensions approximate

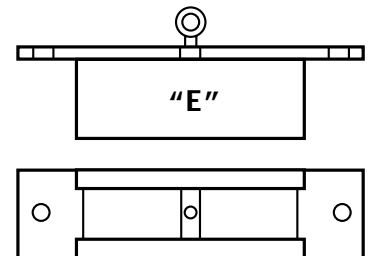

Note: Illustrations are not to scale. See dimensions chart

Magnet Assemblies

Bi-polar assemblies can be used for holding and transferring parts, for aligning pieces during welding operations, and as the holding elements on paint racks. All-welded construction with a stainless-steel cover. No epoxy. Withstands considerable abuse and temperatures up to 600° F.

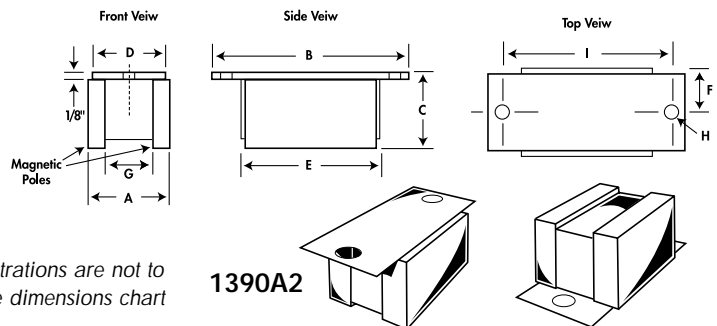

Note: Illustrations are not to scale. See dimensions chart

Bi-Polar Assembly Magnets

Part No.	Pounds Pull	Dimensions/Inches									
		A	B	C	D	E	F	G	H	I	
1390A1	40	0.875	3.250	1.375	0.750	2.000	0.437	0.375	0.281	2.750	
1390A2	55	1.250	3.250	1.375	1.000	2.000	0.625	0.750	0.281	2.750	
1390A3	65	0.875	5.250	1.375	0.750	3.875	0.437	0.375	0.281	4.500	
1390A4	120	1.250	5.250	1.375	1.000	3.875	0.625	0.750	0.281	4.500	
1390A5	250	1.875	5.250	2.125	1.750	3.875	0.937	1.125	0.312	4.500	

Key: A = Width, B = Length, C = Height, D = Back plate width, E = Magnet length, F = Center to edge of magnet, G = Gap width, H = hole size, I = Center to center of hole. All dimensions approximate

Magnet Assemblies

Assemblies can be used for holding and transferring parts, for aligning pieces during welding operations, and as the holding elements on paint racks.

Note: Illustrations are not to scale. See dimensions chart

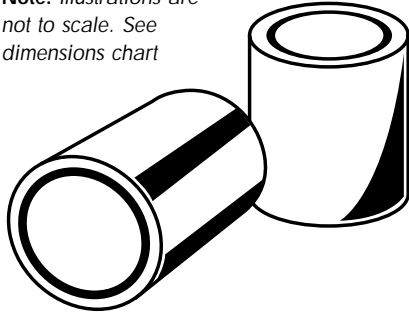

Alnico Assemblies

Alnico assemblies are most useful where heat is a factor. They withstand temperatures of 850° without appreciable loss of power. They should be insulated with a non-ferrous sleeve such as aluminum or brass when pressed into steel. Listed to the right are the most common sizes (other sizes available). Most available with or without tapped hole. Call for details.

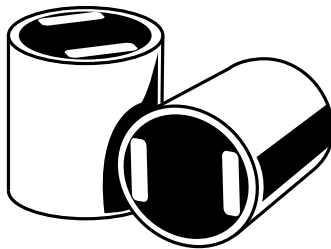

Ceramic Assemblies

Ceramic assemblies use a ferrite magnet encased in an aluminum cup. They should not be used in temperatures higher than 180° F because of the epoxy. They can be pressed into steel without any further insulation.

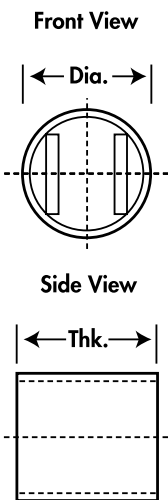
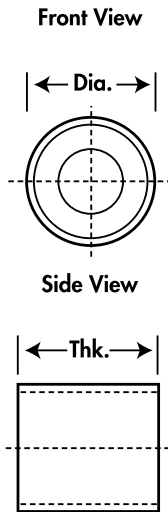

Alnico Assemblies

Part No.	Dimensions/Inches		Approx. Holding Value
	DIA	THK	
9800	0.250	0.500	4.00 oz.
	0.250	0.750	6.00 oz.
9801	0.312	0.500	14.00 oz.
	0.312	0.750	18.00 oz.
	0.312	1.000	20.00 oz.
9802	0.375	0.500	1.50 lb.
	0.375	0.750	1.50 lb.
	0.375	1.000	1.75 lb.
9803	0.500	0.500	2.50 lb.
	0.500	0.750	3.00 lb.
	0.500	1.000	3.50 lb.
9804	0.625	0.500	2.75 lb.
	0.625	0.750	4.25 lb.
	0.625	1.000	4.80 lb.
9805	0.750	0.750	9.15 lb.
	0.750	1.000	9.45 lb.
	0.750	1.250	10.00 lb.
9806	0.875	0.750	13.20 lb.
	0.875	1.000	16.50 lb.
	0.875	1.250	17.30 lb.
9807	1.000	0.750	15.50 lb.
	1.000	1.000	17.00 lb.
	1.000	1.250	19.00 lb.
9808	1.250	0.750	17.50 lb.
	1.250	1.000	21.00 lb.
	1.250	1.250	25.00 lb.

All dimensions approximate

Ceramic Assemblies

Part No.	Dimensions/Inches		Approx. Holding Value
	DIA	THK	
8501	0.375	0.500	1.00 lb.
	0.375	0.750	1.75 lb.
	0.375	1.000	2.25 lb.
8502	0.500	0.500	2.25 lb.
	0.500	0.750	3.00 lb.
	0.500	1.000	3.75 lb.
8504	0.625	0.625	3.75 lb.
	0.625	0.750	4.00 lb.
	0.625	1.000	5.00 lb.
8505	0.750	0.500	5.00 lb.
	0.750	0.750	8.00 lb.
	0.750	1.000	9.50 lb.
	0.750	1.250	10.59 lb.
8507	1.000	0.500	7.00 lb.
	1.000	0.750	9.00 lb.
	1.000	1.000	12.00 lb.
	1.000	1.250	16.00 lb.
8509	1.250	0.750	13.00 lb.
	1.250	1.000	20.00 lb.
	1.250	1.250	24.00 lb.
	1.250	1.500	26.00 lb.

All dimensions approximate

Material Handling Magnets

Multiple-pole magnetic blocks have unlimited uses.

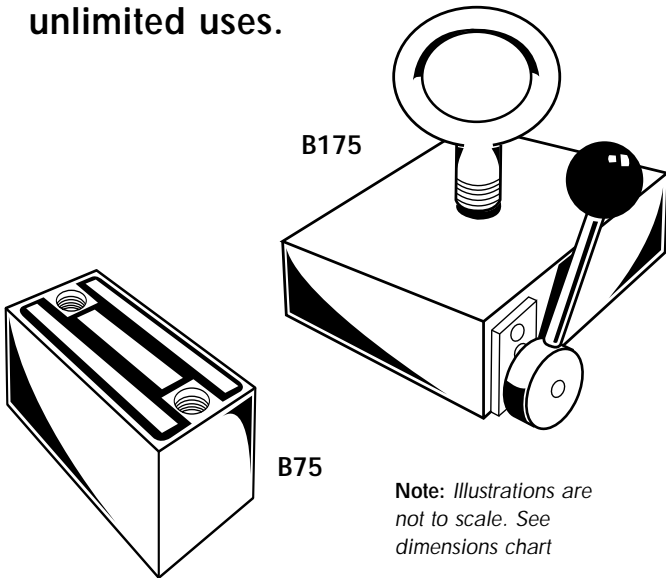

Note: Illustrations are not to scale. See dimensions chart

Magnetic Blocks

Multiple-pole magnetic blocks have mounting holes for attaching to surfaces where magnetic holding devices are needed. Blocks may also be drilled and tapped for fastening to spotlights, shop work lights, service lights, spray nozzles, indicators, etc. Heat tolerant to 180° F. Model B450 is available with or without a cam release and eyebolt. Cam Release and Eyebolt available on B450 only. Must be specified.

Magnetic Blocks

Part No.	Dimensions/Inches				Pound Pull
	H	W	L	D	
B75	1.187	1.312	2.437	2.000	75.0
B125	1.250	1.500	3.375	2.875	125.0
B175	1.312	2.062	3.562	3.000	175.0
B450	1.750	2.875	4.250	**	450.0

Key: W = Width, L = Length, H = Height, D = Distance, ** Holes may be drilled 5/8" deep on back face. All dimensions approximate

Magnetic Grippers

Part No.	Pounds Pull	Weight (lbs.)	Heat Tolerance	Dimensions/Inches		
				H	W	L
M688	280	5.2	180°	1.250	3.000	5.125
M480	400	6.6	180°	1.250	4.500	5.125
M479	600	9.9	180°	1.250	5.250	6.125
BC100	100	2.9	*	1.438	3.500	5.000

Key: W = Width, L = Length, H = Height. * Not recommended for heat applications. All dimensions approximate

Welding Fixtures

No more cumbersome clamps and blocking. Welding Fixtures hold thick or thin gauge steel securely in place for welding or for checking layout. Powerful, permanent magnets are mounted in stainless steel housing. Available with either an adjustable or fixed angle-90°.

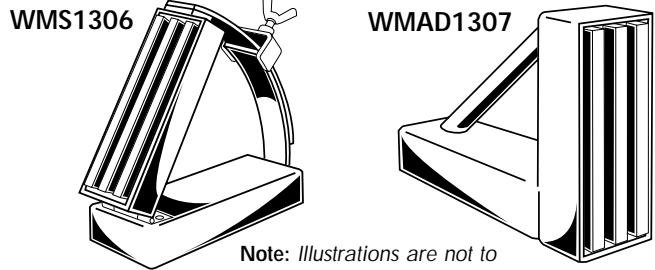

Note: Illustrations are not to scale. See dimensions chart

Welding Fixtures

Part No.	Dimensions/Inches			Weight (lbs.)
	H	W	L	
WMS1306	6.625	1.750	6.375	5.25
WMAD1307	7.250	1.750	7.250	5.50

Key: W = Width, L = Length, H = Height. All dimensions approximate

Grippers

Powerful magnets in the Magnetic Claws give you a positive grip on steel sheets and plates. Although they are designed primarily for sliding and pulling, they can also be used for lifting. A forward push of the handle releases the work. All stainless steel welded construction. Heat tolerant to 180° F.

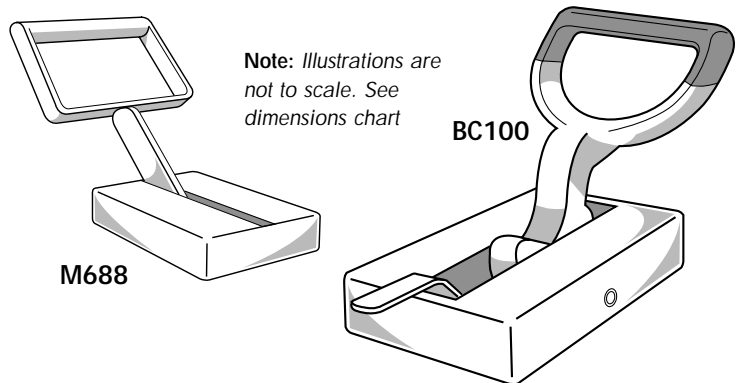

Note: Illustrations are not to scale. See dimensions chart

Standard Ceramic Plate Magnets

Used for removing tramp iron from free-flowing non-magnetic materials such as corn, sugar, flour, gravel, plastic and other granular materials.

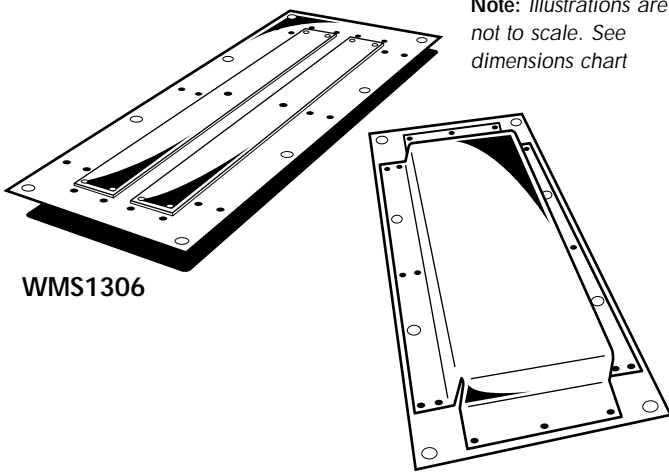

WMS1306

Plate Magnets can be installed in chutes or suspended above conveyor belts and pulleys.

For low volume, lightweight and/or slow-moving applications, we offer a series of light-duty models (listed to the right). These standard ceramic plate magnets are available in single gap design, and are offered in 1" thick (standard) or 1.5" thick (heavy duty) models. The most frequently used sizes are the 14.5", 17.5", and 18.5" lengths.

For more length and depth of magnetic pull, try our heavy duty single or double gap plate magnets listed on the facing page. These models are hinged for ease of cleaning. Models with latches or food grade quality available by special request.

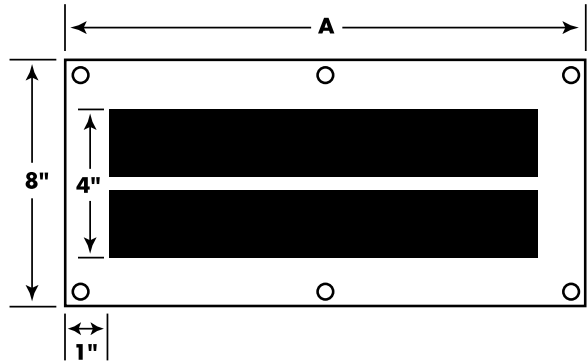

Model TG - Light Duty Plate Magnets

A	Dimensions/Inches				Weight (lbs.)	
	B		SD		Std.	HD
	Std.	HD	Std.	HD		
6					4.2	6.25
7	↑	↑	↑	↑	4.9	7.00
8					5.6	7.50
9					6.3	9.00
10					7.0	10.00
11					7.7	10.50
12					8.4	11.25
13					9.1	12.50
14					9.8	14.00
14.5					10.2	14.25
15					10.5	14.50
16	1	1.5	1.5	2.5	11.2	15.00
17					11.9	16.25
17.5					12.3	16.75
18					12.6	17.00
18.5					12.9	17.50
19					13.3	18.00
20					14.0	19.00
21					14.7	20.00
22					15.4	21.25
23					16.1	22.00
24					16.8	22.50
25					17.5	23.00
28					19.6	25.50
36	↓	↓	↓	↓	25.2	34.50

Key: A = Overall length, B = Thickness, SD = Maximum suspension distance, Std. = Standard, HD = Heavy duty All dimensions approximate

Typical Arrangements

with flow A	against flow B	in vertical position C	<p>Gravity Chutes We recommend when installing the magnet in a chute, to cut the hole to 5" wide by 1" less than the overall length of the magnet.</p>
--------------------	-----------------------	-------------------------------	---

Heavy Duty Ceramic Plate Magnets

Positive tramp iron removal can also be accomplished when Plate Magnets are suspended over belts, chutes, spiked apron feeders and conveyors as illustrated in the diagram "A" below. Hinge allows unit to be lifted for cleaning.

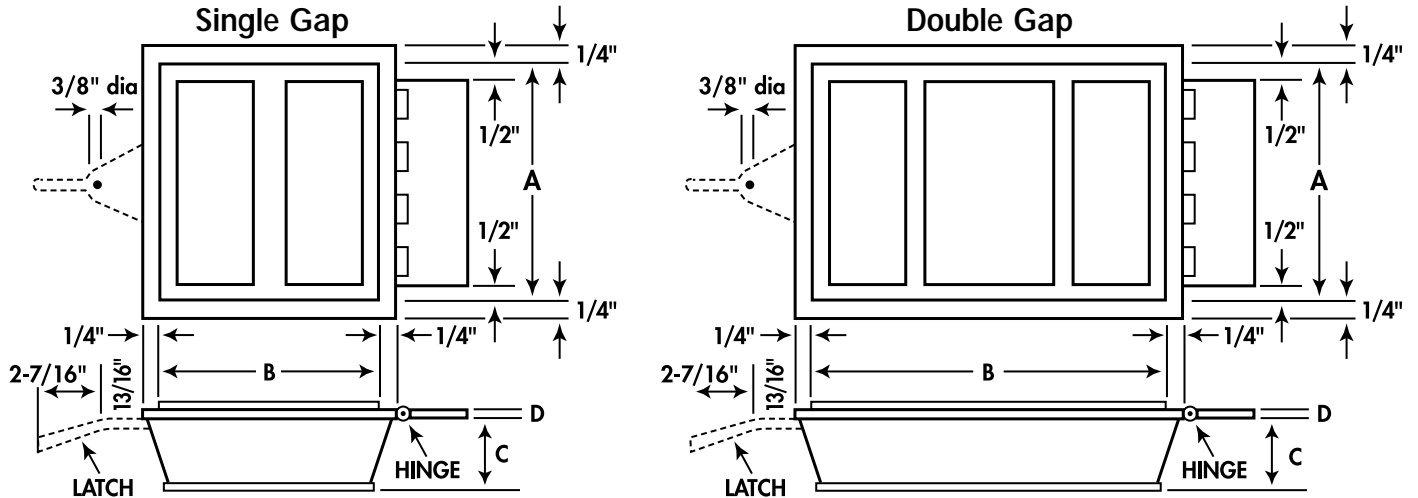

Heavy Duty Ceramic Plate Magnets

Size	Model 15						Model 25						Model 35						Model 45					
	Dimensions/Inches				Weight		Dimensions/Inches				Weight		Dimensions/Inches				Weight		Dimensions/Inches				Weight	
	B		C		(lbs.)		B		C		(lbs.)		B		C		(lbs.)		B		C		(lbs.)	
A	Sngl.	Dbl.	Sngl.	Dbl.	Sngl.	Dbl.	Sngl.	Dbl.	Sngl.	Dbl.	Sngl.	Dbl.	Sngl.	Dbl.	Sngl.	Dbl.	Sngl.	Dbl.	Sngl.	Dbl.	Sngl.	Dbl.	Sngl.	Dbl.
6	▲	▲	▲	▲	8.75	15.75	▲	▲	▲	▲	13.00	25.00	▲	▲	▲	▲	18.75	36.00	▲	▲	▲	▲	40.0	76.0
8					11.50	21.50					17.75	34.00					25.50	49.00					54.0	103.0
10					14.50	27.00					22.25	43.00					32.25	62.25					68.0	130.0
12					17.50	32.50					27.00	51.75					39.00	75.50					82.0	158.0
14					20.50	38.00					31.50	30.75					46.00	88.50					96.0	185.0
16					23.25	43.50					36.25	69.75					52.50	101.75					111.0	210.0
18	6.0	11.0	1.31	.125	26.25	49.25	8.0	15.0	1.43	.125	41.00	78.75	8.0	15.0	2.25	.125	59.50	115.00	10.5	20	3.812	.187	125.0	239.0
20					29.25	54.50					45.50	87.50					66.25	128.00					139.0	266.0
24					35.25	65.75					55.00	105.50					79.75	154.25					167.0	322.0
30					44.00	82.50					69.00	132.50					100.00	193.50					210.0	403.0
36					52.75	99.00					82.75	159.75					121.00	233.00					252.0	485.0
42					61.50	115.50					96.75	186.00					141.50	272.00					295.0	570.0
48	▼	▼	▼	▼	70.25	132.00	▼	▼	▼	▼	110.50	213.00	▼	▼	▼	▼	161.50	318.50	▼	▼	▼	▼	338.0	651.0

Key: A = Width of live area, B = Length of live area, C = Thickness of magnet assembly, D = pole face clearance
All dimensions approximate

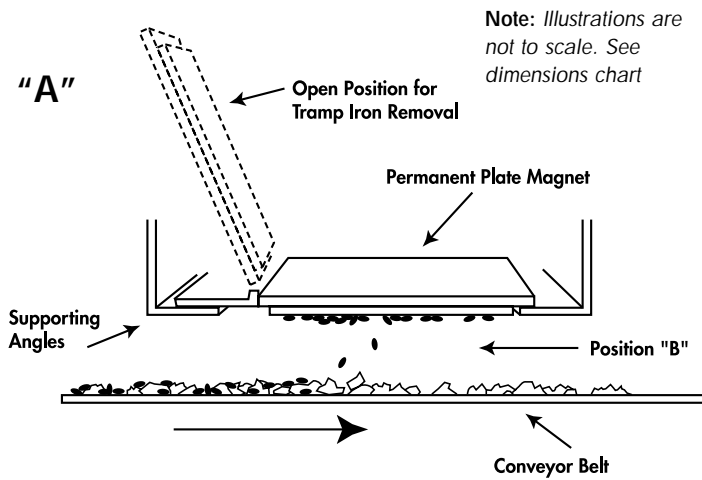

Note: Illustrations are not to scale. See dimensions chart

Model No.	Suspension Distance/Inches
15	1.5 - 2
25	2.5 - 3
35	3.5 - 4
45	4.5 - 5

Maximum recommended belt speed - 250 FPM

Typical Arrangements

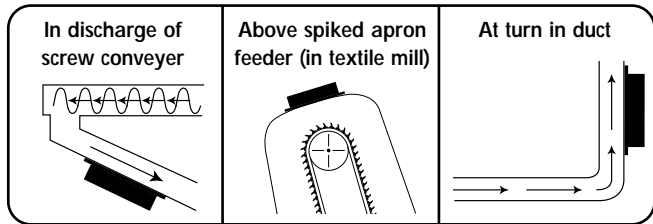

Separation Magnets

Hopper magnets are designed to remove ferrous metal and tramp iron from free-flowing materials such as plastics, foods, cosmetics, grains and minerals.

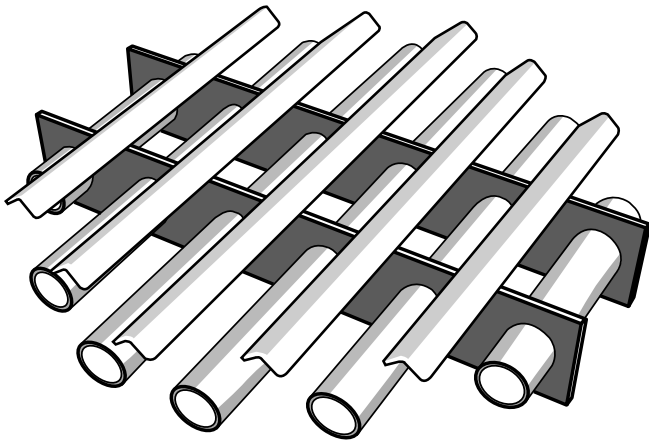

Hopper Grates

High density permanent magnetic tubes are arranged to draw iron particles into the magnetic field and hold them there as material flows through the grate. The grate is removed from the hopper occasionally to be wiped or blown off and then replaced in the hopper to begin collecting again.

The round and rectangular models are available in various sizes to best suit your needs. Round models from 8" to 25" diameter, and rectangular models from 4" to 18". Constructed of stainless steel with one-inch diameter magnetic tubes spaced two inches from center line to center line for greatest magnetic efficiency. Tubes are typically filled with Ceramic magnetic material, but are also available with Alnico or Rare Earth (Neodymium) magnets. Deflectors are placed to direct product flow across the strongest magnetic area. Tubes with or without non-magnetic deflectors are mounted on a rigid frame.

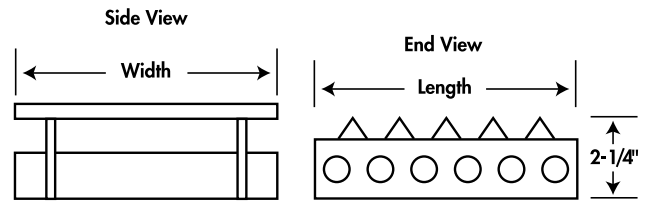

Compare Quality, Strength and Prices!

These magnets are of sturdy welded construction. The one inch tubes contain 7/8" diameter powerful magnets, which makes the magnetic strength of our magnets greater than or equal to that of others on the market. Yet, our prices are typically lower than the smaller diameter, low strength magnets offered by others.

All made to order in round or rectangular shape and with or without deflectors.

NOTE: Magnet should be installed about 2/3 of the way up slope of hopper

Note: Illustrations are not to scale. See dimensions chart

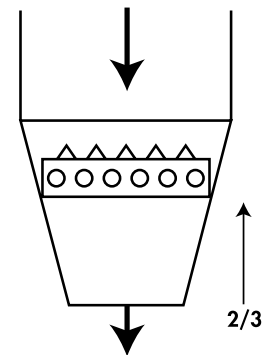

Tubes

The same high-quality tubes used in our hopper grate magnets are available for individual design of grates and other magnetic devices. These 1" diameter tubes can be made with Alnico, Ceramic or Rare Earth magnet material, are manufactured to custom length, and sold by the inch. They also feature 1/4" - 20 tapped aluminum end plugs. Please call for a quote.

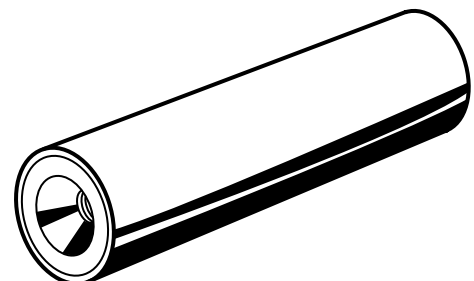

Separation Magnets

Permanent Magnet Pulleys:

- For Separating and Conveying
- Remove Tramp Iron Automatically
- Non-Electric, Permanently Magnetic
- Trouble Free - No Maintenance
- Easily Installed Customized to Fit Your Needs
- Excellent for Can Separators

When material passes over the pulley, ferrous metal objects are attracted by the magnetic field and held tightly as the belt travels around the pulley and are not discharged until they leave the influence of the magnet. Non-magnetic materials follow a normal trajectory. A divider plate can be installed to ensure that no remixing occurs.

Note: Illustrations are not to scale. See dimensions chart

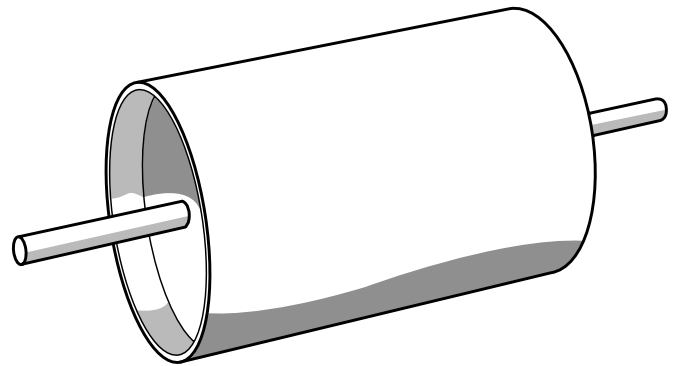
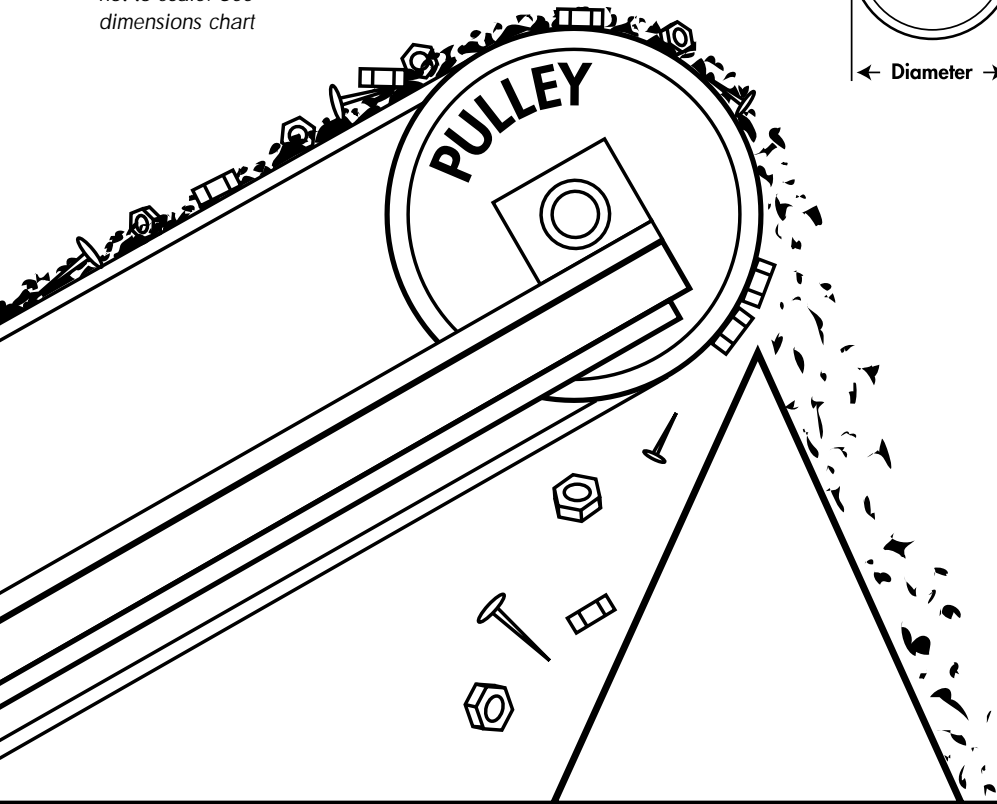

Standard diameters range from 6" to 36". Standard widths range from 10" to 62". Shaft size depends on length and weight.

For quote requests please specify shaft length and diameter (see diagram below), pulley length, pulley diameter, and belt width. Also, please specify the type of material to be processed, approximate rate of flow, and depth of material.

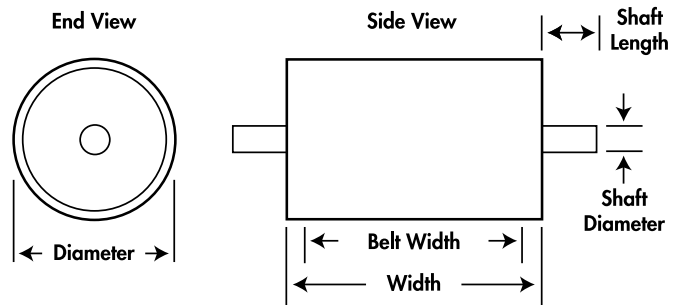

Ferrous objects are held tightly until leaving the influence of the magnet.

Separation Magnets

Magnetic Filters are used where ever ferrous metal particles can appear in hydraulic or lubricating fluids.

Metal particles may be caused by normal machine wear of moving parts, stress flaking, maintenance machining or other factors. These minute particles are abrasive and can cause excessive wear to vital components and premature failure to many systems, if not removed.

Note: Illustrations are not to scale. See dimensions chart

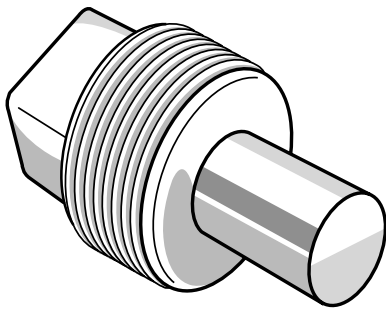

Type 1 - Magnetic Drain Plug Filters

Type 1 filters use the same plugs as standard pipe thread drain plugs except an alnico rod magnet has been inserted into one end. These magnets are normally used in the bottom of a tank or sump; sometimes, they are mounted at the side close to the bottom, and occasionally mounted at the top with a long alnico rod magnet.

Type 1 - Magnetic Drain Plug Filters

Part No.	Standard Drain Size	Magnet Protection
PPA004	1/4" - 18 NPT	1/4" Dia. x 3/8"
PPA005	3/8" - 18 NPT	1/4" Dia. x 3/8"
PPA006	1/2" - 14 NPT	3/8" Dia. x 1/2"
PPA007	3/4" - 14 NPT	3/8" Dia. x 1/2"
PPA008	1" - 11-1/2 NPT	1/2" Dia. x 3/4"
PPA009	1-1/4" - 11-1/2 NPT	1/2" Dia. x 3/4"
PPA010	1-1/2" - 11-1/2 NPT	1/2" Dia. x 3/4"
PPA011	2" - 11-1/2 NPT	1/2" Dia. x 3/4"

NOTE: In some applications, longer lengths of magnets may be used. Clearance and other concerns should be addressed.

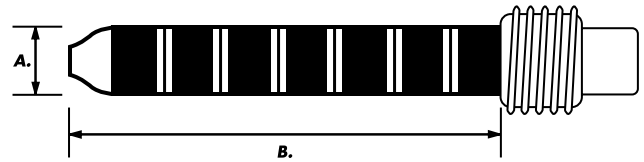

Type 2 - Magnetic Drain Plug Filters

Type 2 filters are made up of strontium ferrite magnets with spacers arranged for maximum strength. These high intensity multi-polar magnetic assemblies are more efficient, lower cost than others available, and designed to clean larger volumes of fluid. Available in lengths from a minimum of 1-3/8" in 1/2" increments all the way to 35 inches.

Type 2 - Magnetic Drain Plug Filters

Part No.	Standard Drain Size	Magnet Projection
PPC.75XL	3/4" - 18 NPT	3/4" Dia. 1-3/8" Min.
PPC1.00XL	1"-11-1/2" NPT	3/4" Dia. 1-3/8" Min.
PPC1.25XL	1-1/4"-11-1/2" NPT	3/4" Dia. 1-3/8" Min.
PPC1.50XL	1-1/2"-11-1/2" NPT	3/4" Dia. 1-3/8" Min.

Drop-In Magnetic Separators

Drop-in magnetic separator filters are designed for fluid tanks and reservoirs to pull fine particles out of fluids and hold them until the unit can be cleaned and dropped back in. Used in tanks or other containers having low to moderate flows. Direct blast of fluids over unit is not recommended. Made to fit your application.

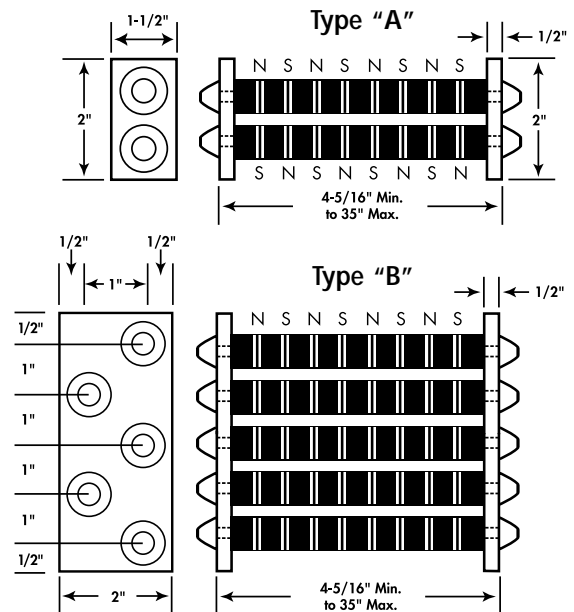

Water Treatment Magnets

Over the past 30 years, magnetic treatment of water has been proven to reduce "hardness" caused mainly by calcium and magnesium.

Water treatment magnets can prevent deposits of these minerals on the inside of pipe walls, and de-scale the existing buildup of solids. Although treatment begins when installed, descaling can take up to six months in heavily crusted pipes. Magnetized water is softer, feels wetter and cleaner, and is free of the additives used in other types of water treatments.

Our magnetic devices for water treatment are specifically designed for installation on various pipe sizes, ranging from 1/4" in diameter to 8" in diameter. These magnets can be used on copper, plastic or steel pipes.

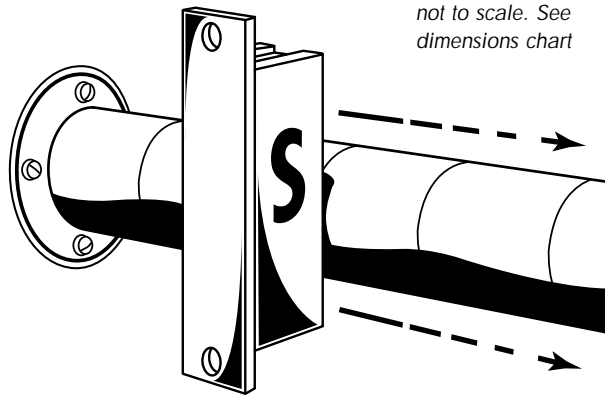

Note: Illustrations are not to scale. See dimensions chart

Assembly Design

For Model No. WTMLM50P

The WTMLM50P water treatment magnet is for all copper or plastic pipes up to 1/2" in diameter. The south pole of the magnet is marked with an "S". Water flow direction should be from North magnetic pole to South magnetic pole. This illustration

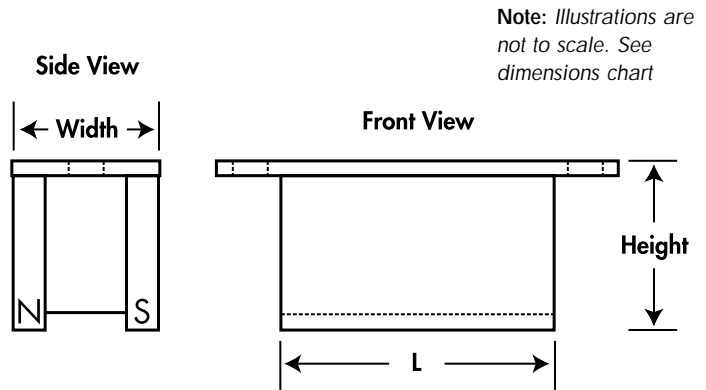

Note: Illustrations are not to scale. See dimensions chart

tion shows the proper application of this magnet to the pipe. Excellent for ice machines, water coolers, refrigerators with ice cube makers, and coffee makers with piped-in water.

All Other Models

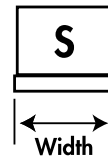
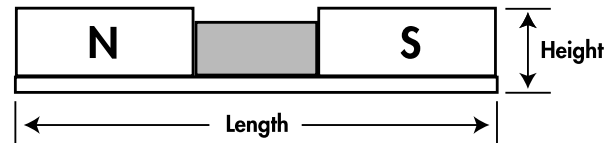

Note: Illustrations are not to scale. See dimensions chart

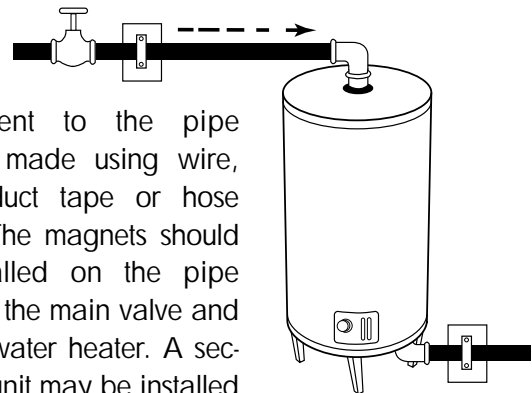

Attachment to the pipe can be made using wire, string, duct tape or hose clamp. The magnets should be installed on the pipe between the main valve and the hot water heater. A secondary unit may be installed on the pipe that exits the water heater, if necessary.

NOTE: 1/2" and 3/4" steel pipes use the same magnets as 1" pipe.

Water Treatment Magnets

Recommended Magnet Arrangements:

- A. Model No. WTM4 2 Magnets Required (poles repelling)
- B. Model No. WTM802 4 Magnets Required (poles repelling)
- C. Model No. WTM1863 4 Magnets Required (poles repelling)
- D. Model No. WTM186 8 Magnets Required (poles repelling)
- E. Model No. WTM186X2 12 Magnets Required (poles repelling)

Note: Illustrations are not to scale. See dimensions chart

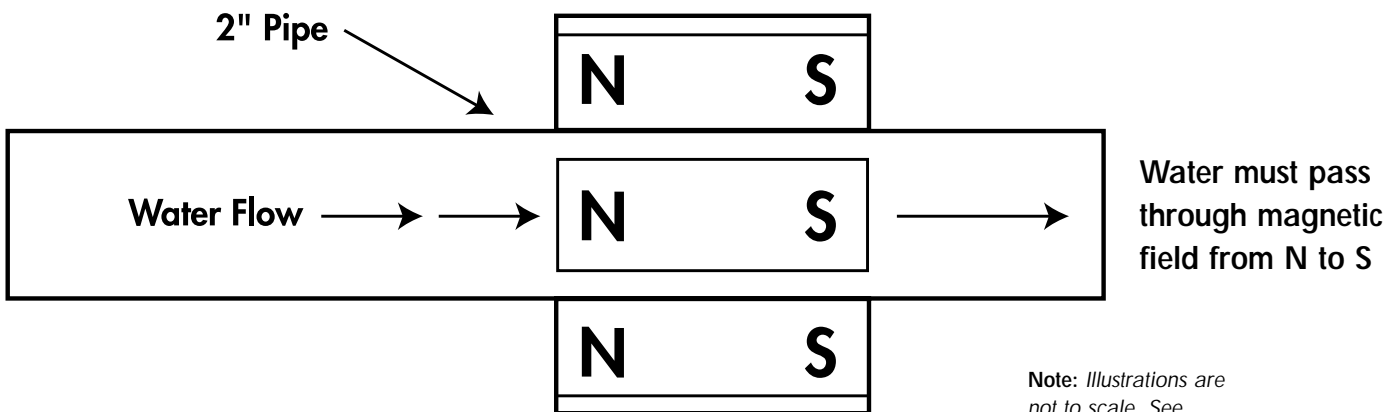
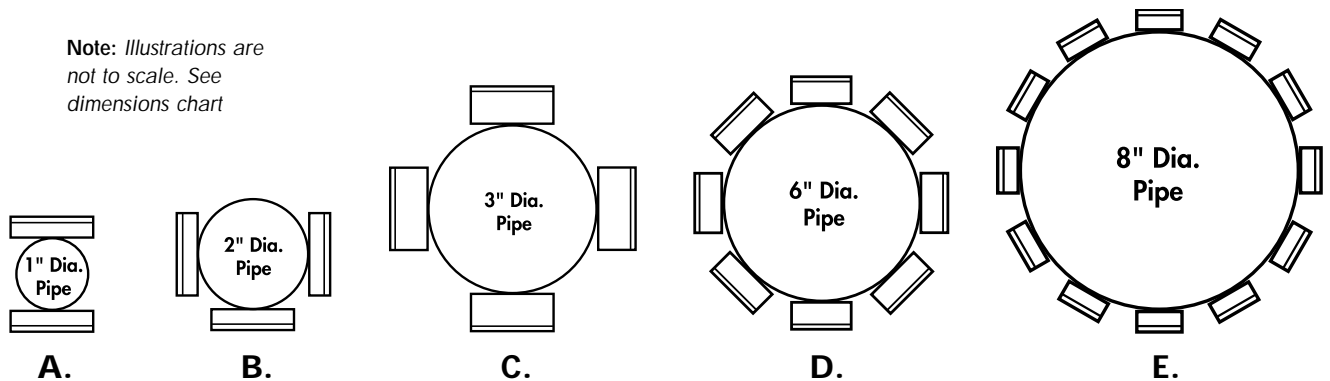

Note: Illustrations are not to scale. See dimensions chart

Water Treatment Magnets

Part No.	Pipe Size	Magnets Needed	Dimensions/Inches			Some Typical Applications
			H	W	L	
WTMLM50P	1/2"	1 - 2	1.06	0.75	2.00	Ice machines, Water Coolers, Instant Water Heaters
WTM4	3/4"	1 - 2	1.00	1.00	4.50	Dishwashers, Boats, Air Conditioners
WTM4	1"	2	1.00	1.00	4.50	Restaurants, Homes, Boats, Solar Panels
WTM802	2"	4	0.68	2.00	7.00	Agricultural Pipe, Car Washes, Spas
WTM1863	3"	4	1.25	2.00	7.00	Factories, Hospitals, Mines, Boilers
WTM186	6"	8	1.25	2.00	13.00	Steel Fabricators, Public Pools, Cooling Towers
WTM186X2	8"	12	2.37	2.00	13.50	Industrial Drainage Pipes, Sewage Treatment Outlet Pipes

Key: W = Width, L = Length, H = Height

All dimensions approximate

Inventory I.D. Magnets

Use magnetic data card holders and flexible magnetic strip to keep track of inventory or stock. These handy magnets are perfect for use in warehouses, stores and stockrooms that are equipped with metal shelving units.

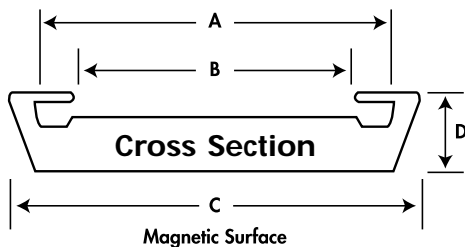

Data Card Holders

These pre-formed magnetic channels are designed to hold pre-printed or hand written data cards which can be paper thin up to 1/32" thick. Use to hold data cards which contain important product information such as part numbers, descriptions, etc. Magnetic data card holders attract to metal surfaces such as shelving units, desks, walls, doors and more. Also use to hold name plates, notices and other important messages. RE10 holds 3/8" wide cards, RE20 holds 13/16" wide cards, RE40 holds 1-5/8" wide cards, RE90 holds 3" wide cards.

Data Card Holders

Part No.	Dimensions/Inches			
	A	B	C	D
RE10	0.400	0.320	0.475	0.125
RE20	0.825	0.650	0.950	0.125
RE40	1.700	1.475	1.830	0.125
RE90	3.015	2.820	3.130	0.140

Key: A. = Width of channel, B. = Viewing area, C. = Overall width, D. = Overall thickness
All dimensions approximate

Flexible Magnetic Strip

A. Uncoated flexible magnetic strip (without adhesive backing) is magnetic on one side only. To use, affix either a computer generated or handwritten adhesive-backed label with product information to the non-magnetic (grooved) side. (See "A" above right)

B. Adhesive Backed flexible magnetic strip can be used to make any paper labels or other inventory tracking devices instantly magnetic. Simply attach the adhesive side of the magnet to the back of the label. Once labels are magnetic, it's easy to relocate them as often as inventory is moved. No more hassles of removing sticky labels! (See "B" below)

C. Vinyl Coated flexible magnetic strip allows product data to be written directly on the vinyl side of the magnet. Use water-based markers for temporary data (they're erasable). Use permanent markers for lasting data. Or, for a more professional look, screen print or pad print your data onto the vinyl side (please contact your local screen printer for this service). (See "C" below)

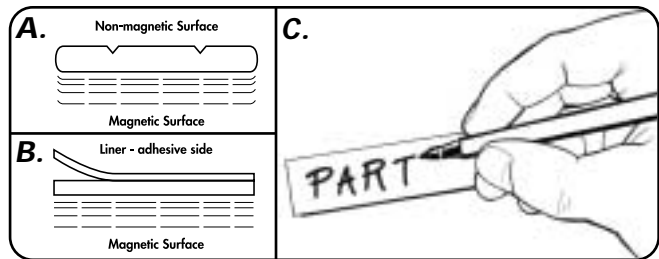

Flexible Strip with or without adhesive backing

Part No.	Dimensions/Inches		
	Thick	Width	Length
ZG10AC	.060	0.5	100 ft. roll
ZG40AC	.060	1.0	100 ft. roll
ZG90AC	.060	3.0	100 ft. roll
ZG60	.060	1.5	100 ft. roll
ZG80	.060	2.0	100 ft. roll
ZG40S3.5	.060	1.0	100 ft. roll*

Key: AC = Adhesive backing, S = magnet has been cut (scored) most of the way through so that the pieces can easily be snapped off.
*Scored every 3-1/2" All dimensions approximate

Flexible Strip with vinyl coating on one side

Part No.	Dimensions/Inches		
	Thick	Width	Length
ZG40W/WKS	.060	1.0	100 ft. roll
ZG03040W/WKS	.030	1.0	200 ft. roll
ZG03080W/WKS	.030	2.0	200 ft. roll
ZG40Y**	.060	1.0	100 ft. roll
ZG03090W/WKS	.030	3.0	200 ft. roll

Key: W/WKS = White vinyl coating on the weak side, uncoated on the magnetic side. ** = Yellow vinyl coating on the weak side, uncoated on the magnetic side.
All dimensions approximate

Office Magnets

These office products are efficient, innovative and cost effective.

Magnetic Hangers

The most convenient way to hang framed pictures, certificates or notices on steel partitions and cabinets. Wide selection of models support from 1-1/2 lb. to 50 lbs.

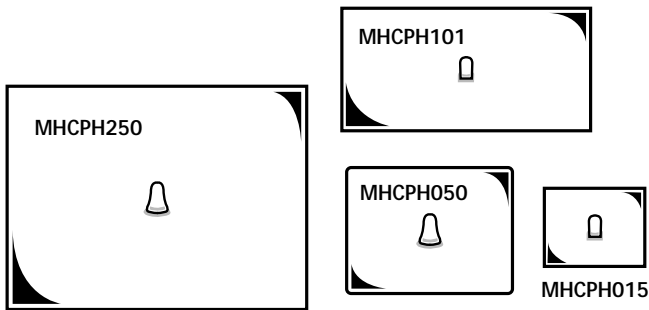

Magnetic Hangers

Part No.	Hold	Size	Approx.	Color
	Rating (lbs.)	(inches)	Weight (lbs.)	
MHCPH015	1.5	1.5 X 2.0	0.05	Beige
MHCPH025	2.5	2 X 3	0.11	Beige
MHCPH050	5.0	3 X 4	0.203	Beige
MHCPH100	10.0	3 X 7	0.38	Beige
MHCPH101	10.0	3.25 X 6.125	0.38	Grey
MHCPH150	15.0	4 X 7	0.44	Beige
MHCPH250	24.0	6 X 9	0.88	Beige
MHCPH500	50.0	9 X 12	1.69	Beige

All dimensions approximate

Magnetic Hooks

Coat Hook

Hang coats, jackets, hats and umbrellas to any steel surface; remove and relocate instantly.

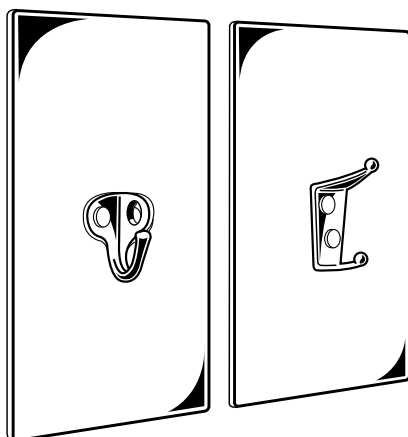

Magnetic Coat Hooks

Part No.	Hold	Size	Approx.	Protrusion
	Rating (lbs.)	Inches	Weight (lbs.)	From Wall (in.)
MH100	10.0	3.125 X 7.625	0.44	2.500
MHCH100	10.0	3.125 X 7.625	0.41	1.750

All dimensions approximate

Note: Illustrations are not to scale. See dimensions chart

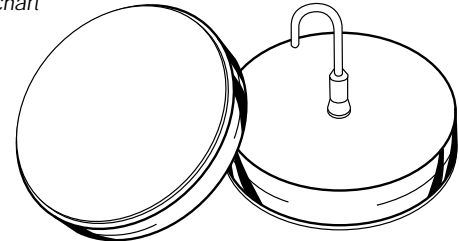

Handi-Hook™

This powerful magnetic assembly with attached hook can lift 20 lbs. in a vertical test. Use it to hang a shop light from the inside of a car hood or metal beam. Hang tools, keys or kitchen utensils from metal doors, refrigerators, filing cabinets or any ferrous metal surface. Its range of shop and household uses are nearly unlimited. Protective liner included to prevent scratching of painted metal surfaces.

Magnetic Handi-Hook™

Part No. MHHH20

Size: 2 in. dia.

Magnetic Clamps and Clips

Cable Clamp holds phone and office machine cords neatly to steel desks, partitions and baseboards. Magnetic clips also hold wiring and cords, in addition to memo pads, clip boards and more.



MHMC030



MHMC015

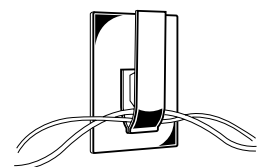

MHCC015B

Magnetic Clamps and Clips

Part No.	Hold	Size	Approx.	Type
	Rating (lbs.)	(inches)	Weight (lbs.)	
MHCC015B	1.5	1.5 X 2.0	0.06	Clamp
MHMC015	1.5	1.5 X 2.0	0.06	Clip
MHMC030	3.0	1 dia.	0.05	Clip

All dimensions approximate

Handy Magnets

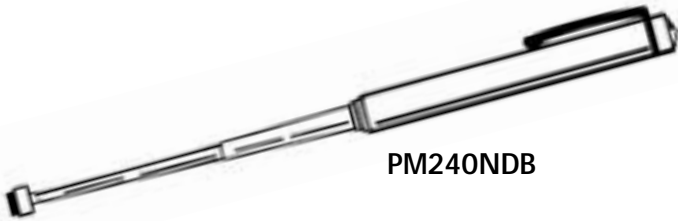

PM240NDB

Handy pickup to retrieve hard-to-retrieve objects. Use as pointer for presentations and lectures.

Telescoping Magnetic Pickup

Lifts 32 times its own weight! This handy telescoping magnetic pickup/pointer extends from 6" to 24" and has a powerful permanent neodymium magnet in the tip. Great for retrieving small metal objects such as nails, screws, washers, small pliers, key rings and more from hard-to-reach places. It also doubles as a presentation pointer with a handy pocket clip attached.

Note: Illustrations are not to scale. See dimensions chart

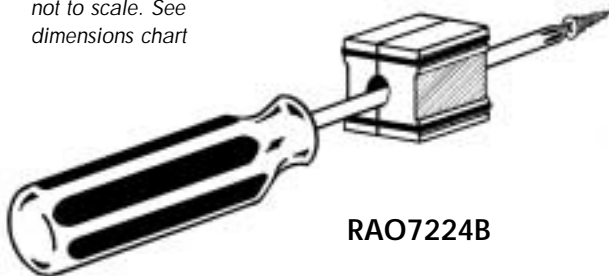

RAO7224B

Screwdriver Magnetizer/Demagnetizer

Quickly and easily make small tools magnetic to keep those hard-to-handle screws and nuts in position. Simply insert a screwdriver; nut runner; etc., into the hole, pull it out, and it's magnetized! For extra magnetic strength, leave the Magnetizer on the tool while in use. Simply pass the tool through one of the channels on the side of the magnet to demagnetize it. Then the tool can be safely used with computers and other magnetically sensitive equipment. It's the perfect accessory for machine shops, manufacturing plants and anywhere people use screwdrivers and other small tools!

Note: Illustrations are not to scale. See dimensions chart

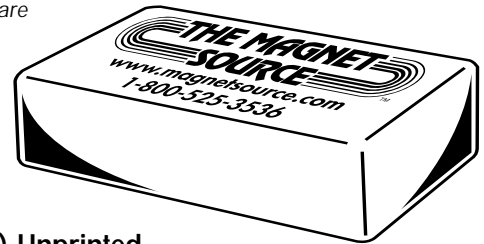

CB60PC-(color)-Unprinted

Hold Everything Magnet

If you're looking for a small, colorful magnet with incredible holding power for industrial or advertising specialty applications, then you need a "Hold-Everything" magnet. Instead of holding a few measly pieces of paper to a metal surface, this magnet can anchor a whole pad (3/8" thk x 3" wide x 3" long)! Each permanent magnet is encased in a colorful plastic cap (12 colors to choose from) that can easily be screenprinted or heat stamped for a lasting impression. Use these magnets to hold up maps, posters, drawings, blueprints, pictures, notes and other important items on ferrous metal surfaces. They even make great paper clip holders for around the office!

Approx. Size: 1" W x 2" L x .5" H

Powerful, permanent magnetism guaranteed 12 brilliant colors: Red, Orange, Yellow, Green, Dark Blue, Light Blue, Medium Blue, Pink, Purple, Silver, Black, and White. Ideal advertising specialty item/giveaway, Perfect for shop, office and home! Made in U.S.A. Available printed with your message or unprinted.

BEND-IT Magnet

This 19" long bendable shaft has a powerful neodymium magnet in the tip making it perfect for retrieving iron objects from really hard-to-reach places.

BI190

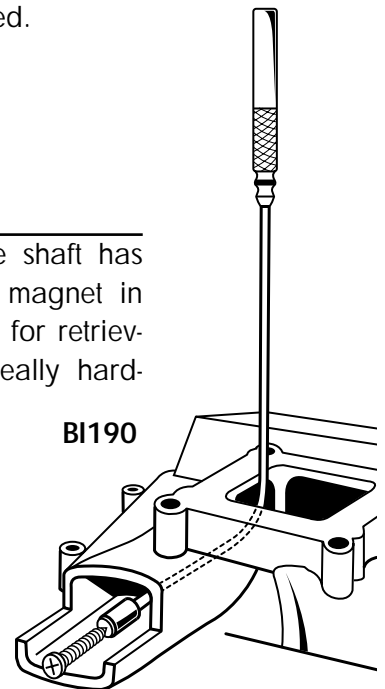

Material Handling Magnets

Pick up, transport and release metal parts. Effective magnets for rapidly lifting and moving small iron and steel parts from stock bins, boxes, kegs, tables or floor.

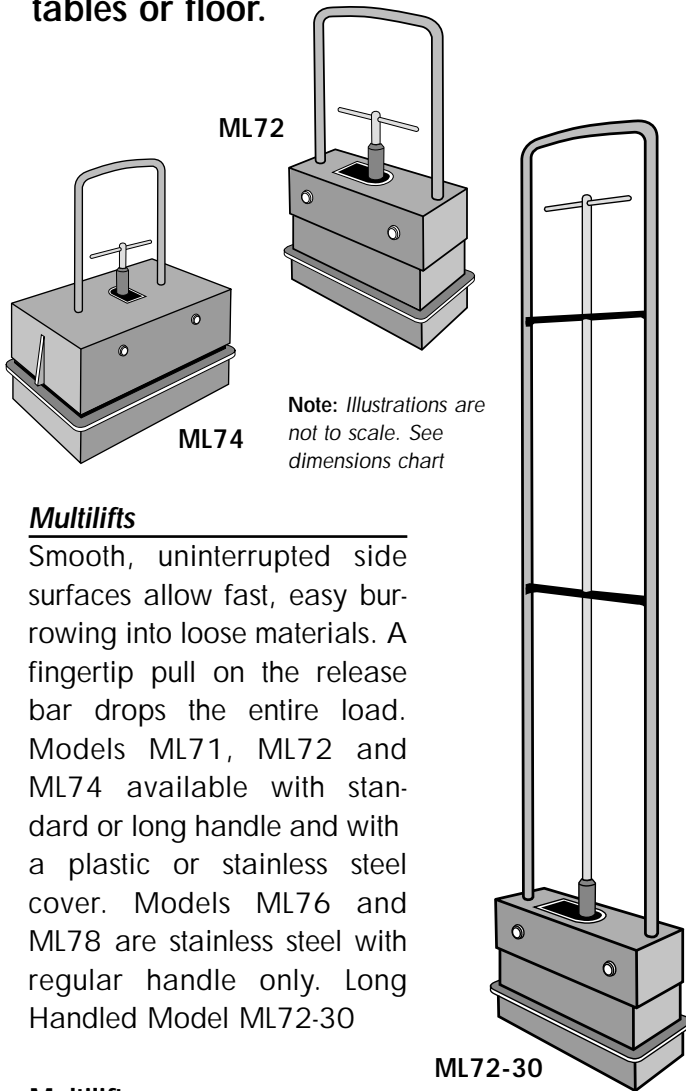

Note: Illustrations are not to scale. See dimensions chart

Multilifts

Smooth, uninterrupted side surfaces allow fast, easy burrowing into loose materials. A fingertip pull on the release bar drops the entire load. Models ML71, ML72 and ML74 available with standard or long handle and with a plastic or stainless steel cover. Models ML76 and ML78 are stainless steel with regular handle only. Long Handled Model ML72-30

Multilifts

Part No.	Weight (lbs.)	Dimensions/Inches			Pound Pull
		W	L	H	
ML71	2.75	1.625	4.750	9.250	2-3
ML72	4.50	3.125	4.375	9.250	4-5
ML74	8.00	4.750	6.250	9.250	8-9
ML76	11.00	4.750	8.500	9.750	10
ML78	15.00	4.750	11.250	9.750	13
ML71-30	6.75	1.625	4.750	34.000	2-3
ML72-30	8.00	3.125	4.750	34.000	4-5
ML74-30	12.00	4.750	6.250	34.000	8-9

Key: W = Width, L = Length, H = Height. All dimensions approximate

Permanent Magnet Lifts

There is never a power failure with these magnet lifts. Because permanent magnets supply the lifting force, they are always ready to go to work. They never need remagnetizing and they are not dependent upon an outside power source.

This safe, permanent magnetic lifting device has a low weight to lifting capacity ratio. Easily portable for use indoors or outdoors. Perfect for handling smooth-surfaced, heavy, solid ferrous metal blocks (Note: Not recommended for sheet lifting).

Safe practice in use of magnetic lifts dictates that maximum working load be no more than half the test load. These magnets have been load tested at twice the safe working load shown in table.

NOTE: Greater magnetic power is needed for lifting cast iron than for the same weight in steel.

Note: Illustrations are not to scale. See dimensions chart

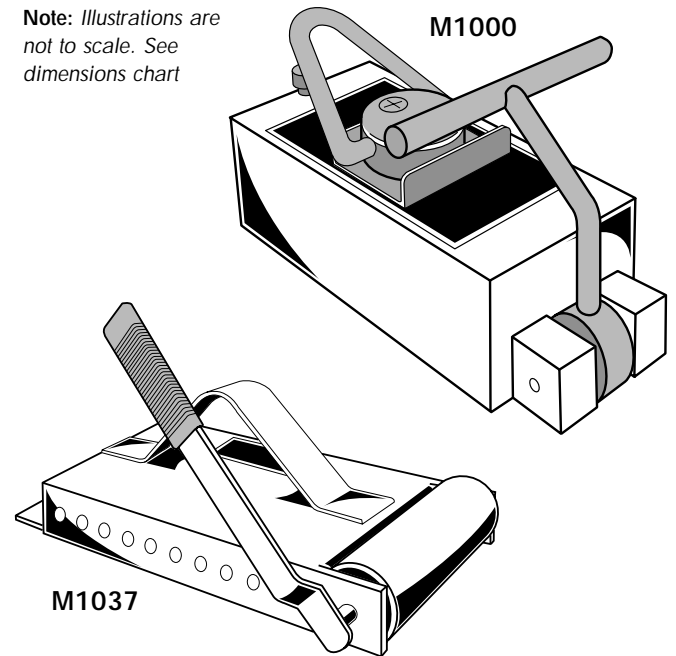

Permanent Magnetic Lifts

Part No.	Weight (lbs.)	Dimensions/Inc			Working Load (lbs.)
		W	L	H	
M1000	33	5.125	12.750	3.625	750
M2000	100	8.500	18.500	4.250	2,000
M1037	26	6.312	13.625	5.500	1,500
M1037JR	16.5	6.312	9.125	4.000	750

Key: W = Width, L = Length, H = Height. All dimensions approximate